

6.5 & 8 VALVES

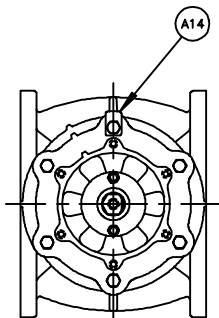

10.5 - 18 VALVES

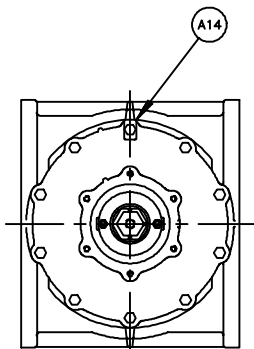

18.5 & 20 VALVES

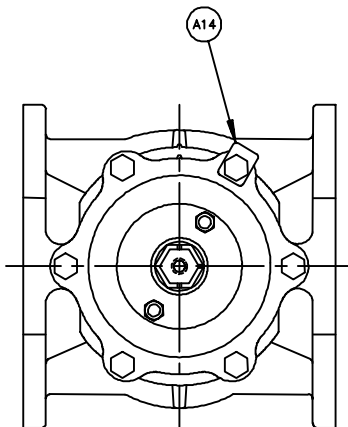

3.5 - 6 VALVES  
(SEE NOTE 4)

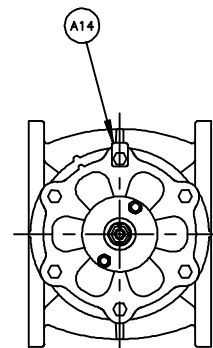

8.5 - 10 VALVES  
(SEE NOTE 4)

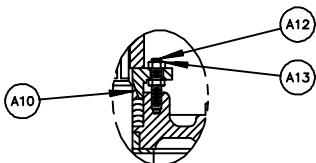

DETAIL "A"  
3.5 - 8 NT CONSTRUCTION

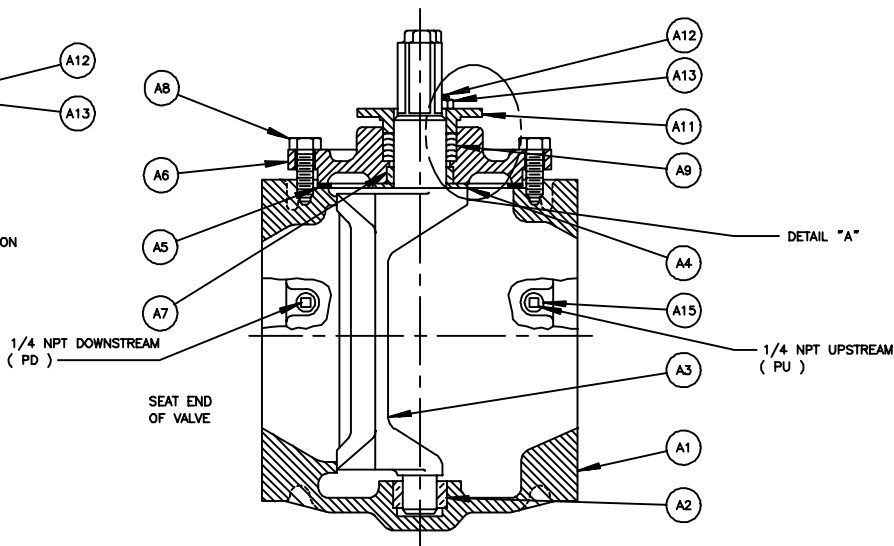

NOTE:

1. RECOMMENDED SPARE PARTS ARE ITEMS NUMBER A3, PLUG(IF RUBBER FACED), A4, A5 AND A9.
2. WHEN ORDERING PARTS, INCLUDE VALVE SIZE AND PART NUMBER FROM DATA PLATE. ALSO INCLUDE THIS DRAWING NUMBER WITH PART NAME, NUMBER AND QUANTITY.
3. CLOCKWISE ROTATION OF PLUG STEM CLOSES VALVE.
4. ON THE SIZE 3.5, 4, 4.5, 5, 6, 8.5, & 10 VALVES BONNET SCREWS ARE USED FOR MOUNTING ACTUATOR.

NO	PART NAME	QTY
A1	BODY	1
A2	BEARING (3.5 - 8 VALVES)	1
A2	BEARING (8.5 - 18 VALVES)	2
A2	BEARING (18.5 & 20 VALVES)	1
A3	PLUG	1
A4	THRUST BEARING	1
A5	GASKET (BODY)	1
A6	BONNET	1
A7	BEARING	1
A8	SCREW (3.5 - 18 VALVES)	6
A8	SCREW (18.5 & 20 VALVES)	10
A9	PACKING	-
A10	CONE, 3.5 - 8 NT (EXCEPT LOW FRICTION CAT. CHAR. NBRL & SQ. PACKING)	1
A11	GLAND	1
A12	STUD (3.5 - 20 GS--HD_ & GS--CW_)	2
A12	STUD (3.5 - 20 GS--C_)	2
A12	STUD (8.5 - 12 MNA)	NOT REQD
A12	STUD (8.5 - 12 LV)	NOT REQD
A12	STUD (3.5 - 20 GS--ML_)	2
A12	STUD (3.5 - 8 NT)	2
A12		
A12		
A13	NUT (3.5 - 20 GS--HD_ & GS--CW_)	2
A13	NUT (3.5 - 20 GS--C_)	2
A13	NUT (8.5 - 12 MNA)	NOT REQD
A13	NUT (8.5 - 12 LV)	NOT REQD
A13	NUT (3.5 - 12 GS--ML_)	2
A13	NUT (3.5 - 8 NT)	4
A13		
A13		
A14	CAUTION TAG	1
A15	PIPE PLUG (PU OR PD ONLY)	-

K	03/08	10/19/02	J	04/03	03/20/06	H	06/03	07/17/06	G	10/06	09/03/06	F	05/07	03/22/05	E	05/12	03/03/03	D	01/11	03/09/01	C	10/78	07/05	B	10/78	11/22/82	A	14/70	05/28/81
---	-------	----------	---	-------	----------	---	-------	----------	---	-------	----------	---	-------	----------	---	-------	----------	---	-------	----------	---	-------	-------	---	-------	----------	---	-------	----------

**DeZURIK**  
 SARTELL, MINNESOTA, U.S.A. 58377  
 CAMBRIDGE, ONTARIO, CANADA  
 SUNBURY, VICTORIA, AUSTRALIA  
 CRANLINGTON, ENGLAND

PEC ECCENTRIC VALVE ASSEMBLY 3.5 - 20, FLANGED, EXCEPT BODY MATERIAL CIS		DOCT. CODE C1	DRAWN CMM	APPROVED RJP	DATE 10-13-83	A-20730
CHECKED TNB						