

PUMP INFORMATION

Model NO: _____
 Rating: _____ GPM _____ TDH
 Motor: _____ HP _____ RPM
 Elec: _____ PH _____ HZ _____ v
 Elec: _____ FL AMPS

DISCHARGE PIPE

- 3"
- 4"

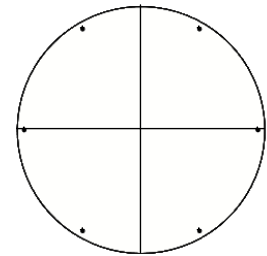
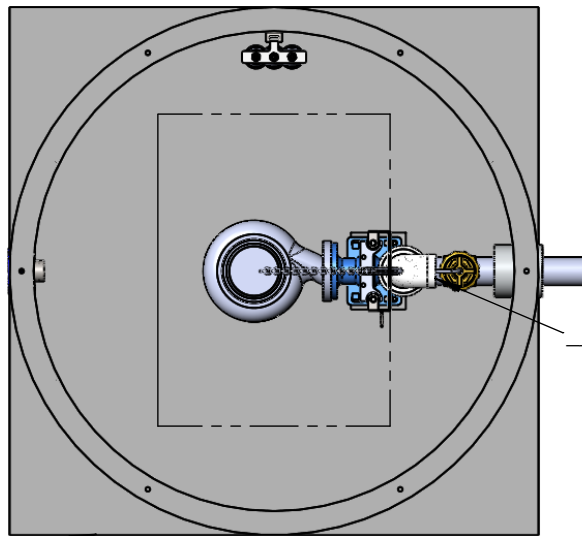

Solid Cover

- Fiberglass
- Steel

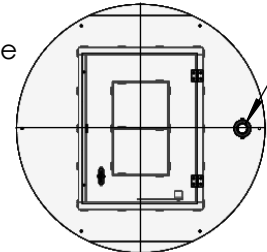

Hinged and Lockable Cover

- Fiberglass
- Aluminum
- Steel

- Anti-Floatation Flange
- Fiberglass Encapsulated
 - ASTM A-36 Steel
 - Round Fiberglass

___ Tee

___ NPT Vent Flange

